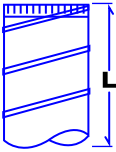
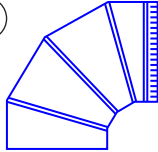
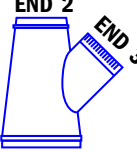
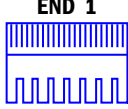
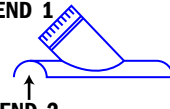
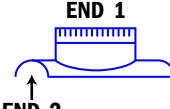
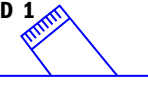
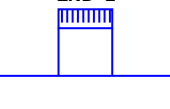
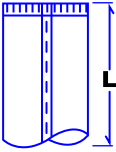
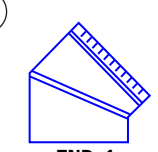
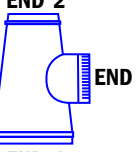
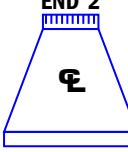
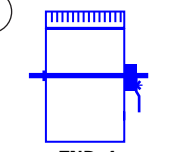
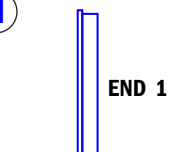
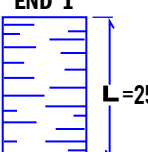
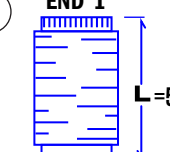
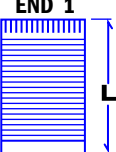
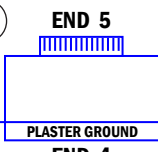
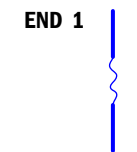
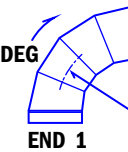

CUSTOMER: _____ JOB NAME: _____ JOB ADDRESS: _____

PHONE: _____ DUE DATE: _____

EMAIL: _____ PICK UP DELIVERY

ROUND FORM

A  END 1 SPIRAL L=10'	B  END 1 90° ADJ. ELBOW	C  END 2 END 3 END 1 T-WYE	D  END 1 START COLLAR	E  END 1 END 2 45° SADDLE TAP	F  END 1 END 2 90° SADDLE TAP	G  END 1 45° FLAT SADDLE TAP	H  END 1 90° FLAT SADDLE TAP
I  END 1 KD PIPE L=36"	J  END 1 45° ADJ. ELBOW	K  END 2 END 3 END 1 TEE	L  END 2 END 1 SUREFIT TAPER	M  END 1 3/8 DAMPER	N  END 1 END CAP	O  END 1 L=25' FLEX DUCT	P  END 1 L=5' FLEX DUCT W/ COLLARS
Q  END 1 L=6' ALUMINUM FLEX BARE / WARP	R  END 5 PLASTER GROUND END 4 CEILING BOX	S  END 1 FLEX CONNECTOR	T  DEG R END 1 SPOT WELDED 90° ELBOW	CODE: <input type="checkbox"/> SMACNA <input type="checkbox"/> UMC <input type="checkbox"/> CMC	LEEDS WRAP: Yes <input type="checkbox"/> No <input type="checkbox"/>	EXPOSED: Yes <input type="checkbox"/> No <input type="checkbox"/>	MATERIAL TYPE: <input type="checkbox"/> Galvanized <input type="checkbox"/> Paint-Lock <input type="checkbox"/> Aluminum 3003 H14 <input type="checkbox"/> 304 Stainless Steel #2B <input type="checkbox"/> 304 Stainless Steel #4 <input type="checkbox"/> Black Iron / CRS

#	QTY	STYLE	END 1	END 2	END 3	END 4	END 5	R-VALUE			DEG	R	LINER		REMARKS / SPECIAL	OTHER FITTINGS / ACCESSORIES
1						X		R4.2 <input type="checkbox"/>	R6 <input type="checkbox"/>	R8 <input type="checkbox"/>			1" <input type="checkbox"/>	1 1/2" <input type="checkbox"/>		
2						X		R4.2 <input type="checkbox"/>	R6 <input type="checkbox"/>	R8 <input type="checkbox"/>			1" <input type="checkbox"/>	1 1/2" <input type="checkbox"/>		
3						X		R4.2 <input type="checkbox"/>	R6 <input type="checkbox"/>	R8 <input type="checkbox"/>			1" <input type="checkbox"/>	1 1/2" <input type="checkbox"/>		
4						X		R4.2 <input type="checkbox"/>	R6 <input type="checkbox"/>	R8 <input type="checkbox"/>			1" <input type="checkbox"/>	1 1/2" <input type="checkbox"/>		
5						X		R4.2 <input type="checkbox"/>	R6 <input type="checkbox"/>	R8 <input type="checkbox"/>			1" <input type="checkbox"/>	1 1/2" <input type="checkbox"/>		
6						X		R4.2 <input type="checkbox"/>	R6 <input type="checkbox"/>	R8 <input type="checkbox"/>			1" <input type="checkbox"/>	1 1/2" <input type="checkbox"/>		
7						X		R4.2 <input type="checkbox"/>	R6 <input type="checkbox"/>	R8 <input type="checkbox"/>			1" <input type="checkbox"/>	1 1/2" <input type="checkbox"/>		
8						X		R4.2 <input type="checkbox"/>	R6 <input type="checkbox"/>	R8 <input type="checkbox"/>			1" <input type="checkbox"/>	1 1/2" <input type="checkbox"/>		
9						X		R4.2 <input type="checkbox"/>	R6 <input type="checkbox"/>	R8 <input type="checkbox"/>			1" <input type="checkbox"/>	1 1/2" <input type="checkbox"/>		
10						X		R4.2 <input type="checkbox"/>	R6 <input type="checkbox"/>	R8 <input type="checkbox"/>			1" <input type="checkbox"/>	1 1/2" <input type="checkbox"/>		
11						X		R4.2 <input type="checkbox"/>	R6 <input type="checkbox"/>	R8 <input type="checkbox"/>			1" <input type="checkbox"/>	1 1/2" <input type="checkbox"/>		
12						X		R4.2 <input type="checkbox"/>	R6 <input type="checkbox"/>	R8 <input type="checkbox"/>			1" <input type="checkbox"/>	1 1/2" <input type="checkbox"/>		

#	QTY	STYLE	END 1	END 2	END 3	END 4	END 5	R-VALUE			DEG	R	LINER		REMARKS / SPECIAL	OTHER FITTINGS / ACCESSORIES
								R4.2	R6	R8			1"	1½"		
13						X		R4.2 <input type="checkbox"/>	R6 <input type="checkbox"/>	R8 <input type="checkbox"/>			1" <input type="checkbox"/>	1½" <input type="checkbox"/>		
14						X		R4.2 <input type="checkbox"/>	R6 <input type="checkbox"/>	R8 <input type="checkbox"/>			1" <input type="checkbox"/>	1½" <input type="checkbox"/>		
15						X		R4.2 <input type="checkbox"/>	R6 <input type="checkbox"/>	R8 <input type="checkbox"/>			1" <input type="checkbox"/>	1½" <input type="checkbox"/>		
16						X		R4.2 <input type="checkbox"/>	R6 <input type="checkbox"/>	R8 <input type="checkbox"/>			1" <input type="checkbox"/>	1½" <input type="checkbox"/>		
17						X		R4.2 <input type="checkbox"/>	R6 <input type="checkbox"/>	R8 <input type="checkbox"/>			1" <input type="checkbox"/>	1½" <input type="checkbox"/>		
18						X		R4.2 <input type="checkbox"/>	R6 <input type="checkbox"/>	R8 <input type="checkbox"/>			1" <input type="checkbox"/>	1½" <input type="checkbox"/>		
19						X		R4.2 <input type="checkbox"/>	R6 <input type="checkbox"/>	R8 <input type="checkbox"/>			1" <input type="checkbox"/>	1½" <input type="checkbox"/>		
20						X		R4.2 <input type="checkbox"/>	R6 <input type="checkbox"/>	R8 <input type="checkbox"/>			1" <input type="checkbox"/>	1½" <input type="checkbox"/>		
21						X		R4.2 <input type="checkbox"/>	R6 <input type="checkbox"/>	R8 <input type="checkbox"/>			1" <input type="checkbox"/>	1½" <input type="checkbox"/>		
22						X		R4.2 <input type="checkbox"/>	R6 <input type="checkbox"/>	R8 <input type="checkbox"/>			1" <input type="checkbox"/>	1½" <input type="checkbox"/>		
23						X		R4.2 <input type="checkbox"/>	R6 <input type="checkbox"/>	R8 <input type="checkbox"/>			1" <input type="checkbox"/>	1½" <input type="checkbox"/>		
24						X		R4.2 <input type="checkbox"/>	R6 <input type="checkbox"/>	R8 <input type="checkbox"/>			1" <input type="checkbox"/>	1½" <input type="checkbox"/>		
25						X		R4.2 <input type="checkbox"/>	R6 <input type="checkbox"/>	R8 <input type="checkbox"/>			1" <input type="checkbox"/>	1½" <input type="checkbox"/>		
26						X		R4.2 <input type="checkbox"/>	R6 <input type="checkbox"/>	R8 <input type="checkbox"/>			1" <input type="checkbox"/>	1½" <input type="checkbox"/>		
27						X		R4.2 <input type="checkbox"/>	R6 <input type="checkbox"/>	R8 <input type="checkbox"/>			1" <input type="checkbox"/>	1½" <input type="checkbox"/>		
28						X		R4.2 <input type="checkbox"/>	R6 <input type="checkbox"/>	R8 <input type="checkbox"/>			1" <input type="checkbox"/>	1½" <input type="checkbox"/>		
29						X		R4.2 <input type="checkbox"/>	R6 <input type="checkbox"/>	R8 <input type="checkbox"/>			1" <input type="checkbox"/>	1½" <input type="checkbox"/>		
30						X		R4.2 <input type="checkbox"/>	R6 <input type="checkbox"/>	R8 <input type="checkbox"/>			1" <input type="checkbox"/>	1½" <input type="checkbox"/>		
31						X		R4.2 <input type="checkbox"/>	R6 <input type="checkbox"/>	R8 <input type="checkbox"/>			1" <input type="checkbox"/>	1½" <input type="checkbox"/>		
32						X		R4.2 <input type="checkbox"/>	R6 <input type="checkbox"/>	R8 <input type="checkbox"/>			1" <input type="checkbox"/>	1½" <input type="checkbox"/>		
33						X		R4.2 <input type="checkbox"/>	R6 <input type="checkbox"/>	R8 <input type="checkbox"/>			1" <input type="checkbox"/>	1½" <input type="checkbox"/>		
34						X		R4.2 <input type="checkbox"/>	R6 <input type="checkbox"/>	R8 <input type="checkbox"/>			1" <input type="checkbox"/>	1½" <input type="checkbox"/>		
35						X		R4.2 <input type="checkbox"/>	R6 <input type="checkbox"/>	R8 <input type="checkbox"/>			1" <input type="checkbox"/>	1½" <input type="checkbox"/>		
36						X		R4.2 <input type="checkbox"/>	R6 <input type="checkbox"/>	R8 <input type="checkbox"/>			1" <input type="checkbox"/>	1½" <input type="checkbox"/>		